

The image is a composite of two construction site photographs. The left side is a blue-tinted image showing a large-scale concrete formwork system with workers on a high-rise structure. The right side is a red-tinted image showing a similar formwork system from a different angle, with a worker visible. A white diagonal line separates the two images.

allform™

SINGLE SYSTEM, ENDLESS SOLUTIONS

www.apacheip.com



Table of Contents

04 Projects

05 Introduction

07 Panels

08 Right Angle Corners
Hinged Corners
Standard Fillers

09 Adjustable Fillers & Corners
Custom Fillers & Forms

10 Standard & Filler Clamp
Accessory Clips & Assemblies

11 Alignment & Lifting Bars
Stacking & Lifting Clamp

12 Pipe Braces & Struts
Bulkhead/Positioning Clip
Dry Tie/Hold Down Bracket

13 Form Ties & Insert Systems
Overlap Corner Bracket

14 Walkway Bracket
Personnel Tie-Off Accessories

15 Ringlock Scaffolding

16 Engineering Support

17 Shoring Components (Future Release)



THE NEXT LEVEL OF FORMWORK.

ALLFORM offers the latest product innovations to the concrete construction industry and was designed from the ground up with production and safety in mind. The result is a single system with numerous advantages over older concrete formwork technologies.

The development team uses smart design and simple solutions to address the obstacles that often delay and complicate projects. The result is a highly versatile concrete forming and shoring system. Perfect for a wide range of infrastructure, industrial and commercial applications, ALLFORM is proprietary technology that drives increased productivity, lower costs and enhances safer field operations.

ALLFORM SAVES YOU MONEY



Light Weight

Reduced labor costs



Fewer Pieces

Reduced material and labor costs



No Welds

Significantly reduced project cost related to damaged material



Better Concrete Finish

Reduced finishing costs



Smart Tie Placement

Reduced labor costs

PANELS

- **CAST STEEL CORNERS** Built to handle tough jobsite conditions.
- **NO WELDS** All components have bolted connections for added strength. Individual damaged components are replaceable.
- **ACCESSORIES CAN BE ATTACHED ANYWHERE** on the form, to horizontal or vertical members.
- **BACKSIDE TIE HOLE ACCESS** Ties and plugs can be moved freely; all tie assemblies are placed **AFTER** both sides of wall formwork are set.
- **LIGHT WEIGHT YET STRONG** Aluminum frame. Just over 5 pounds per SQFT, light enough to handset, but strong enough to gang form.
- **POWDER-COATED FRAMES** Easy cleaning and increased panel life.
- **SYNTHETIC FACING** Stronger with a much longer useful life span than conventional plywood. Will not delaminate or swell, and provides a smoother finish.
- **TIE HOLES EVERY 12"** so different height panels can be placed across from each other.
- **TIES CAN BE ADDED** to achieve a higher pour rate.
- **ALL PANELS ARE SYMMETRICAL** No confusing panel orientation.

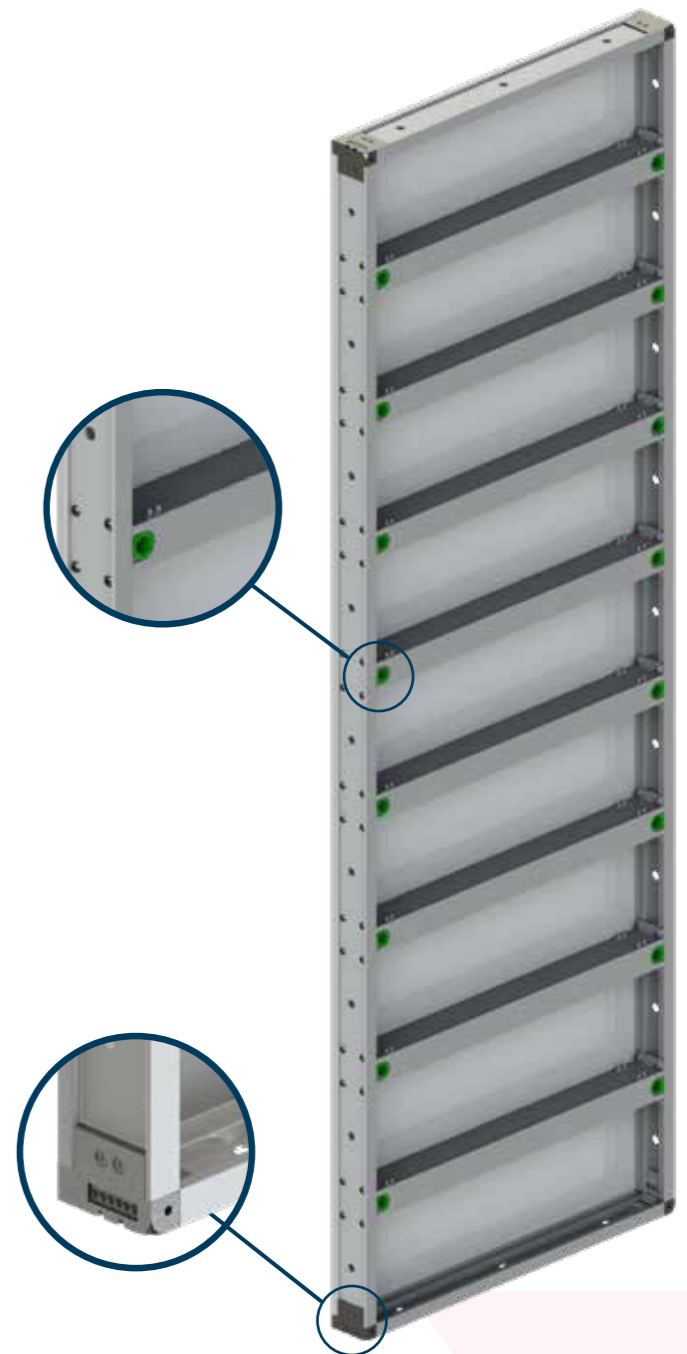

ALL PANELS ARE IMPERIAL, AND AVAILABLE IN THE FOLLOWING SIZES:

Width: 1.5' | 2' | 2.5' | 3' | 4'

Height: 9' | 6' | 4'

RIGHT ANGLE CORNERS

- Inside and outside corners are aluminum extrusions with bolted steel brackets; light weight yet strong
- Inside corner dimensions: 8" x 8"; 4" filler/corner extensions are bolted or clamped to create 12" corner legs
- 4" extension includes tie ports providing additional options for tie alignment
- Outside corner includes shear plates for increased capacity



HINGED CORNERS

- Inside corner dimensions: 8" x 8"; 4" Stripping hinges are bolted to create 12" corner legs; provides option for triple hinge to ease stripping
- Inside corner can be pinned at set angle (135°, etc.)
- Outside corner swings freely to create the desired angle
- Same heights as standard panels: 9', 6', and 4'



STANDARD FILLERS

- 4" stripping hinge and 4" filler/corner extension can be used individually as filler
- 4" filler/extension can be bolted together to create an 8" rigid filler
- Attaches to all panels with either a standard clamp or filler clamp
- Same heights as standard panels: 9', 6', and 4'



ADJUSTABLE FILLERS & CORNERS

- Minimum of 12" and larger adjustable corner legs
- Minimum of 8" and larger adjustable filler widths
- Eliminates the need to inventory numerous sized rigid fillers and corners
- Pre-assembled and shipped to jobsite; uses various grades of facing material to meet design requirements
- Can be adjusted to size at the jobsite
- Same heights as standard panels: 9', 6', and 4'
- Eliminates the need for wood shims at corners and other conditions



CUSTOM FILLERS & FORMS

- Create an unlimited range of custom size and shape panels
- Utilizes adjustable filler components with custom lumber rails and desired facing
- Utilizes CAD technology to create the required inner rail templates for CNC milling or manual woodworking operations
- Custom formwork panels pre-assembled and shipped to jobsite



STANDARD & FILLER CLAMP

- All clamps attach anywhere horizontal or vertical on the interior of panels or gangs
- Have backside plate for accessory attachment
- Accessories pre-assembled to clamp and shipped ready for use
- Clamp jaws have 10 points of contact; creates enough lateral strength to minimize external alignment (walers)
- Clamp connects fast to formwork panels using wing nut to activate clamp jaws
- Use standard clamp for connecting panels together to create gangs
- Use filler clamps to add wood shimming up to 6" in width



ACCESSORY CLIPS & ASSEMBLIES

- One-way clip for primary pipe brace anchor foot; substitute two-way clips for smaller loads
- Two-way clip + STD Clamp assembly for pipe brace head; pre-assembled and shipped ready for use
- Two-way clip + STD Clamp for alignment or lifting bar assemblies; eliminates duplicate clamps when used at panel joints



ALIGNMENT & LIFTING BARS

- Lifting capacity is higher than other systems
- Protects panel top rail from damage, unlike other systems
- Provides vertical alignment when stacking panels; horizontal alignment when required for long gangs



STACKING & LIFTING CLAMP

- Alternative to using alignment/lifting bars
- Use for lifting gangs or for alignment when stacking panels
- Quick assembly with single wing nut for tightening clamp to inner-rail or end-rail joint
- Includes attachment point for pipe brace



PIPE BRACES & STRUTS

Lengths

- 3'- 5'
- 6'- 9'
- 10'- 19'
- Use one-way clip foot anchor and two-way clip + clamp assembly for top brace attachment to formwork panels; optional top attachment for stacking clamp or walkway bracket



BULKHEAD/POSITIONING CLIP

- Use to anchor the panel bases or gang against uplift loads
- Position base of formwork gangs for alignment to desired dimensional location
- Connect to horizontal overlapping panels by screwing into synthetic facing
- Attach bulkhead form inside panels where wall pour terminates

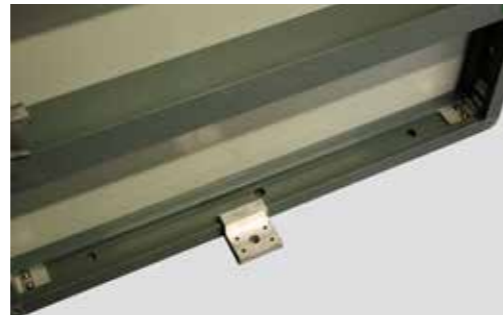

DRY TIE/HOLD DOWN BRACKET

- Use with dry tie assembly on top or side of wall formwork
- Doubles as a hold-down bracket for anchoring against uplift loads



FORM TIES & INSERT SYSTEMS

- Unlike other systems, ALLFORM ties can be installed AFTER both sides of wall formwork are set, since all tie components install from the back side of the panels
- Ties with rebar interference can easily be moved and open tie ports plugged
- ALLFORM can handle tie rod with sleeves, she-bolts with inner rods or taper ties
- Since all panels have tie holes at 12" centers, all height panels (9', 6', and 4') can be tied across from one another



OVERLAP CORNER BRACKET

- Overlap corner brackets are used with standard panels and eliminates the need for multi-purpose panels. This provides a better concrete finish with less inventory items.
- Standard width panels (4', 3', 2.5' and 2') are used for columns and corners
- The overlap bracket is adjustable in 1" increments
- Since the panel tie holes are at 12" centers, additional brackets can be added to increase pour rates in taller columns



WALKWAY BRACKET

- Attached anywhere on the interior of a panel or gang with integrated standard clamps
- No additional hardware required to attach to vertical or horizontal panel configurations
- Pipe braces can be attached directly to the underside of the walkway bracket; eliminates interference of bracing inside working area



RINGLOCK SCAFFOLDING

- Ringlock style scaffolding (including board brackets) can be attached directly to ALLFORM
- By incorporating Ringlock, ALLFORM can provide 360° worker access and maintain continuous 100% tie-off capability, even on complex configurations
- ALLFORM is the only system available that allows for direct connection of Ringlock or other similar style system scaffolding material



PERSONNEL TIE-OFF ACCESSORIES

- All personnel tie-off components have been tested to meet OSHA anchorage requirements
- All personnel tie-off devices can be attached on any horizontal inner-rail or rail joint between two panels
- Personnel tie-off bracket is pre-assembled at required worker access locations prior to placement of formwork gang
- Lanyard tie-off accessory connects to industry standard harnesses with shock-absorbing lanyards; use double lanyards to maintain 100% tie-off while climbing formwork
- Lanyard tie-off accessory designed with a safety trigger to allow easy worker movement while climbing formwork; includes an integrated shock absorber for added safety



ENGINEERING SUPPORT

- ALLFORM is supported by experienced industry engineers who can assist with project designs, take-offs, site consultations or other technical support
- ALLFORM component library is available in 2D AutoCAD or 3D Tekla Structures environment; other formats are available as required
- Tekla Structures is an advanced structural BIM software that lets you create, combine, manage and share multi-material 3D models packed with valuable construction information
- Use Tekla Structures for conceptual planning through field fabrication. All ALLFORM components are Tekla compatible, allowing you to generate individual BOMs, required site inventory by phase, material cycling sequences and preassembly schedules, along with accurate 3D models.
- Reduce material waste and ensure a more efficient workflow by pairing ALLFORM's engineering support with your next ALLFORM project

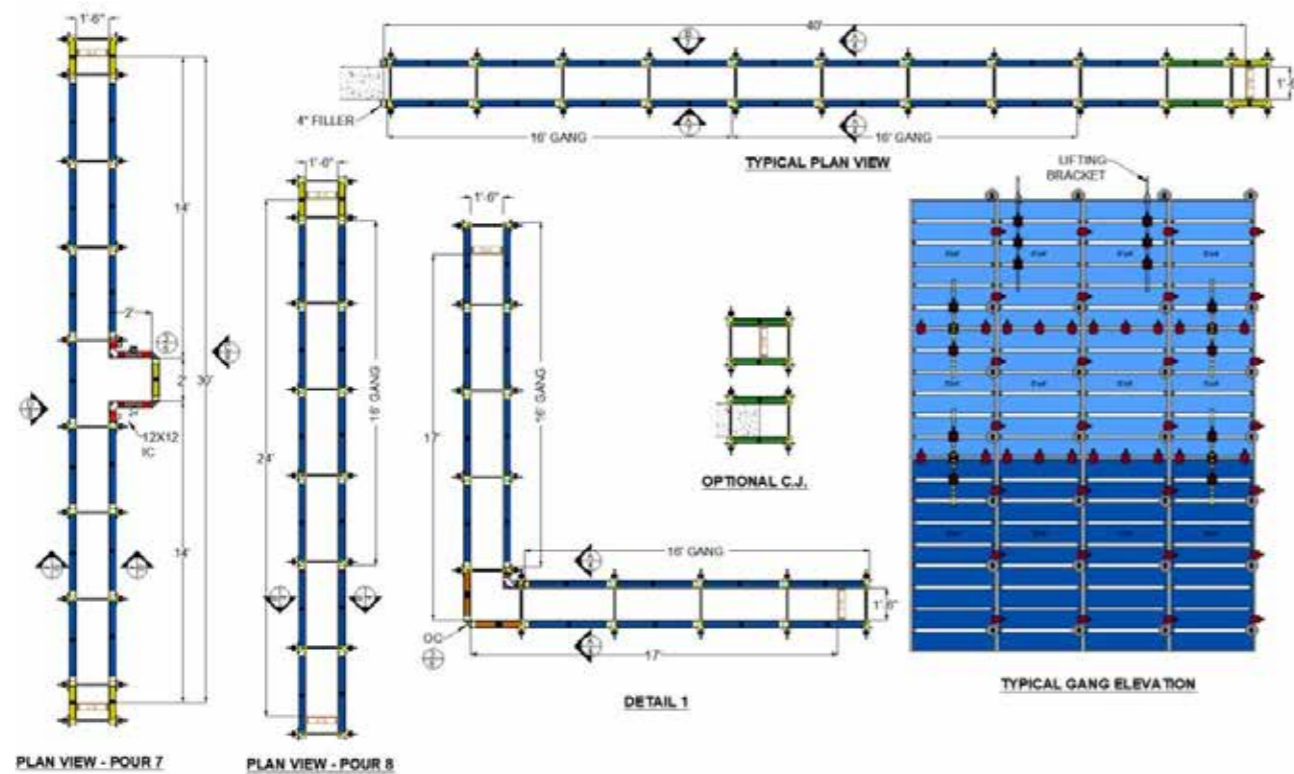
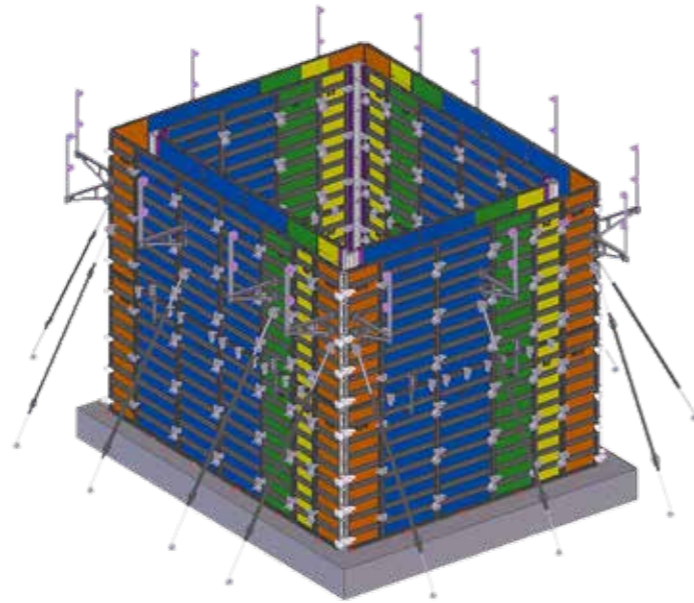

SHORING COMPONENTS (FUTURE RELEASE)

- A planned release of shoring components will integrate seamlessly with forming components
- Non-welded aluminum component construction provides higher capacity and can be configured for use as conventional, drop-deck, table ganged or heavy duty shoring
- Use forming panels as slab decking or use shoring to create braced frames for formwork gang assemblies
- Bracing panels double as load bearing members or can be cantilevered to efficiently handle edge conditions
- All decking members can be cantilevered past supports to efficiently handle internal wall or column obstructions
- The combination of both forming and shoring components will satisfy an even wider range of industrial, infrastructure or commercial applications, ranging from handset to heavy duty ganged assemblies

Contact the ALLFORM team to learn more about any planned releases





SINGLE SYSTEM, ENDLESS SOLUTIONS

Visit or Contact Us

Address

Apache Industrial Services
250 Assay Street, Suite 500
Houston, Texas 77044

Phone

713.450.9307

Email

allform@apachip.com

Website

www.apacheip.com

